



JOSAM play detectors

A necessity before the wheel alignment...



AM 900 K

First-rate and versatile equipment is required to determine wear and tear on wheel suspension and steering systems.

To obtain reliable results when carrying out wheel and axle measuring on vehicles, it is essential to first check for any excessive play.

The play detectors from Josam do this job in a matter of minutes.

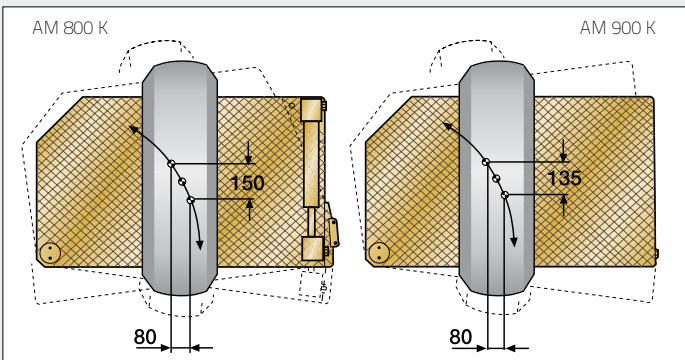

The design of the plates permits circular movement which can detect any play in both axial and radial directions.

The wheel moves forwards, backwards as well as sideways.

The play detectors are simple to install and are secured in place by three expansion shell bolts.

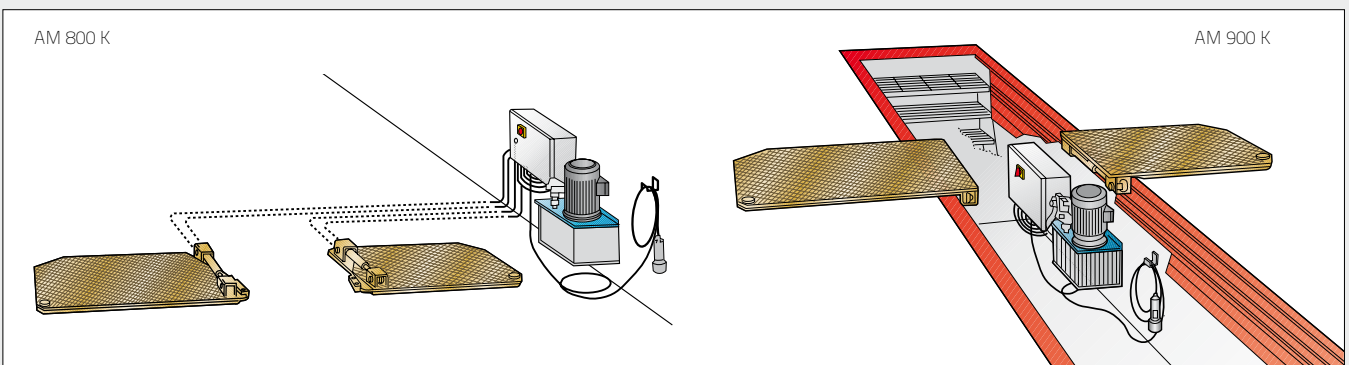

AM 800 K can be installed either directly on the floor or over the service pit.

AM 900 K, designed with its hydraulic cylinders in a downward position, is installed exclusively over the service pit.

The JOSAM play detectors can be used for checking trucks, semi trailers, trailers, passenger cars as well as buses.

Before the axle is checked for possible play, it is placed on the plates and the brake is applied.

The operator steers the movement of the plates by means of a control handle. This control mechanism includes a halogen lamp which makes it easy to spot any play in the wheel suspension.

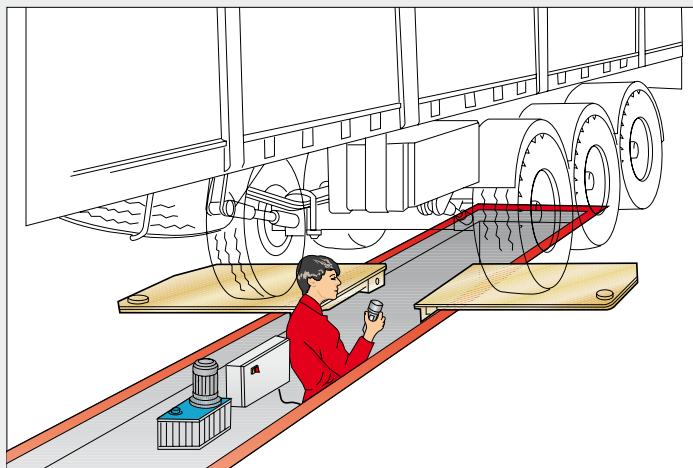

Checking rigid rear axles

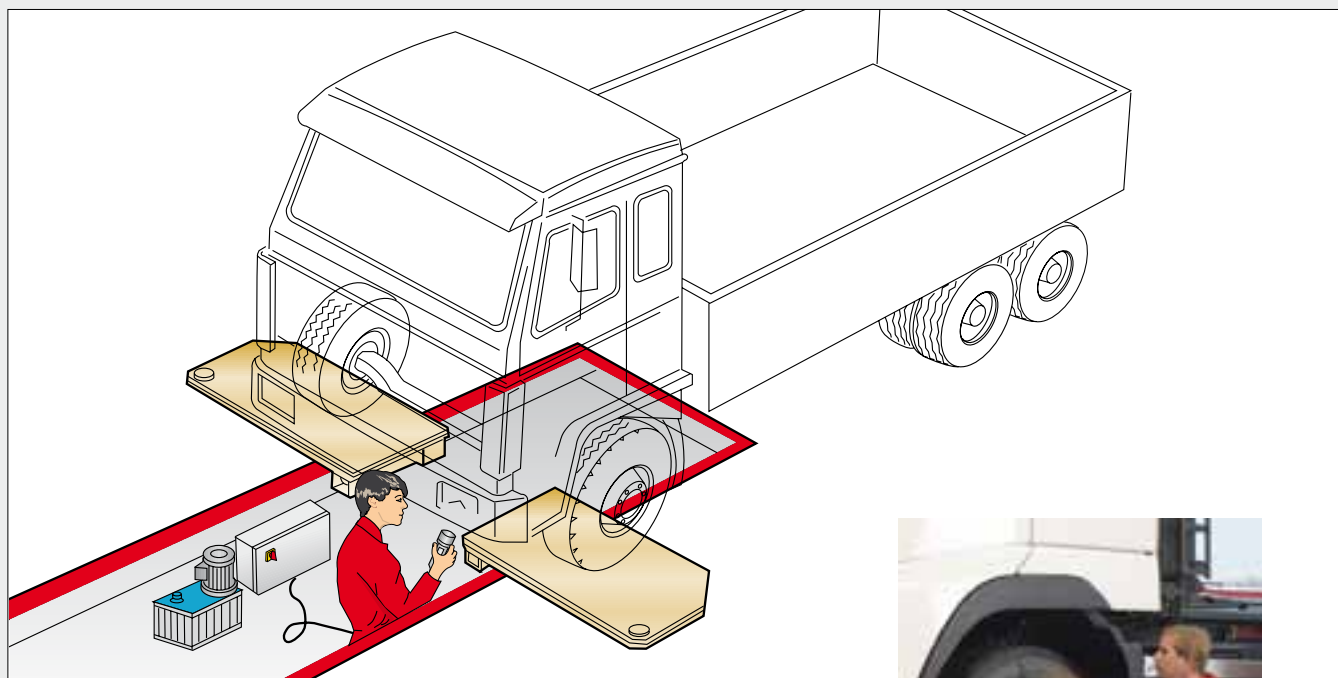

Checking front axles



Article number	Description
AM 800 K	Play detector for floor or pit
AM 900 K	Play detector for pit
AM 975 K	Hose kit for play detector

Technical data

Max axle pressure: Dynamic load 13 tons. Static load 20 tons

Mains voltage: 3 x 400 V standard 50 Hz. (Alternative voltage delivered to order)

Sideway play: ~ 80 mm (AM 800 K) ~80 mm (AM 900 K)

Longitudinal play: ~150 mm (AM 800 K) ~135 mm (AM 900 K)

Representative:

Manufacturer:



JOSAM[®]

Box 419 ■ SE-701 48 ÖREBRO ■ Sweden
Tel.: +46 19 30 40 00 ■ Fax +46 19 32 03 16
E-mail: info@josam.se ■ Internet: www.josam.se